

Vývěvy s bočními kanály G_serie

Typová řada 2BH1

Standardní řada dmychadel
pro nasávaná množství až 2000 m³ / hod a tlakové diference do 600 mbar

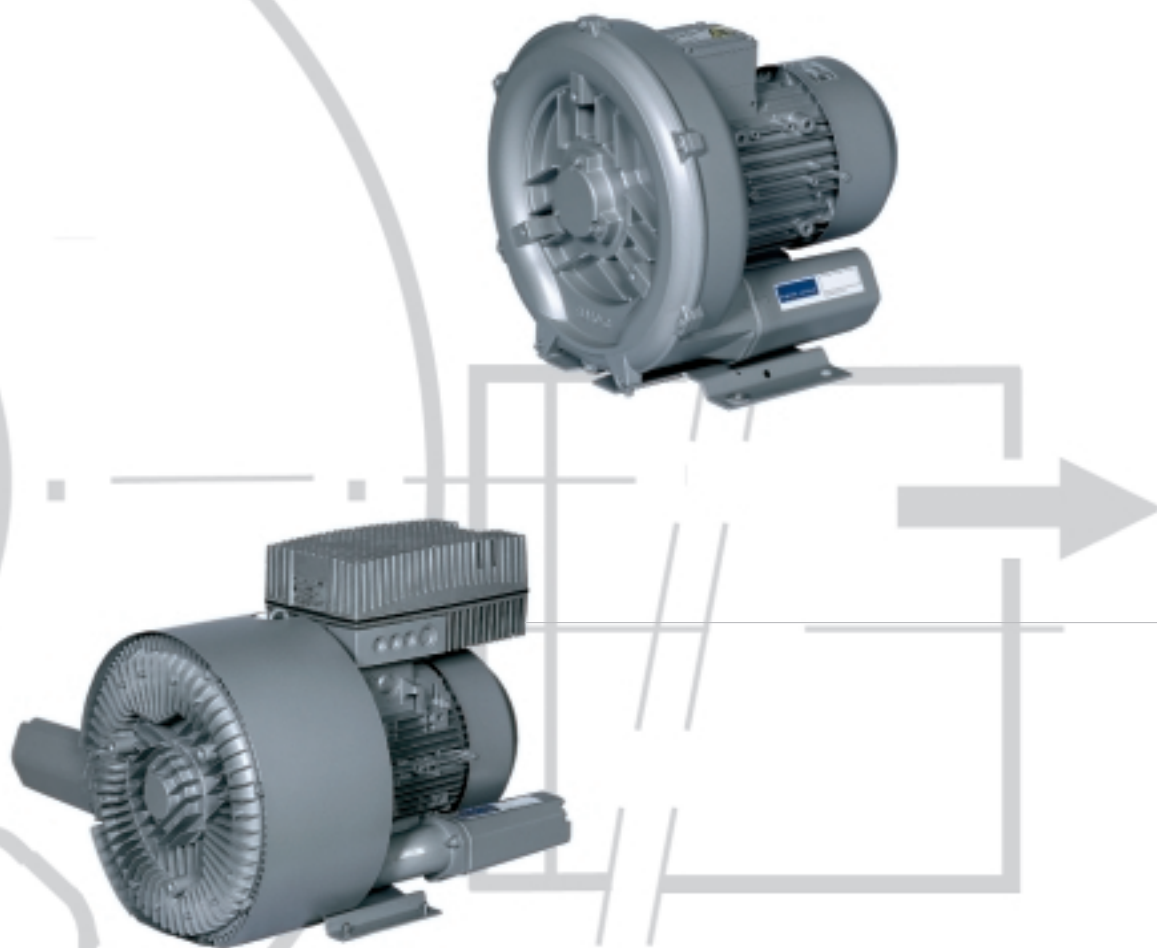

G_Serie , typová řada 2BH1, 50 Hz



Pracovní křivky platí pro přepravu vzduchu o teplotě 15°C na sání při atmosférickém tlaku 1 013 mbar s tolerancí + - 10%.
Celková tlaková diference platí pro teplotu nasávaného vzduchu a teplotu okolí 25°C.

Pracovní křivky - vývěvy

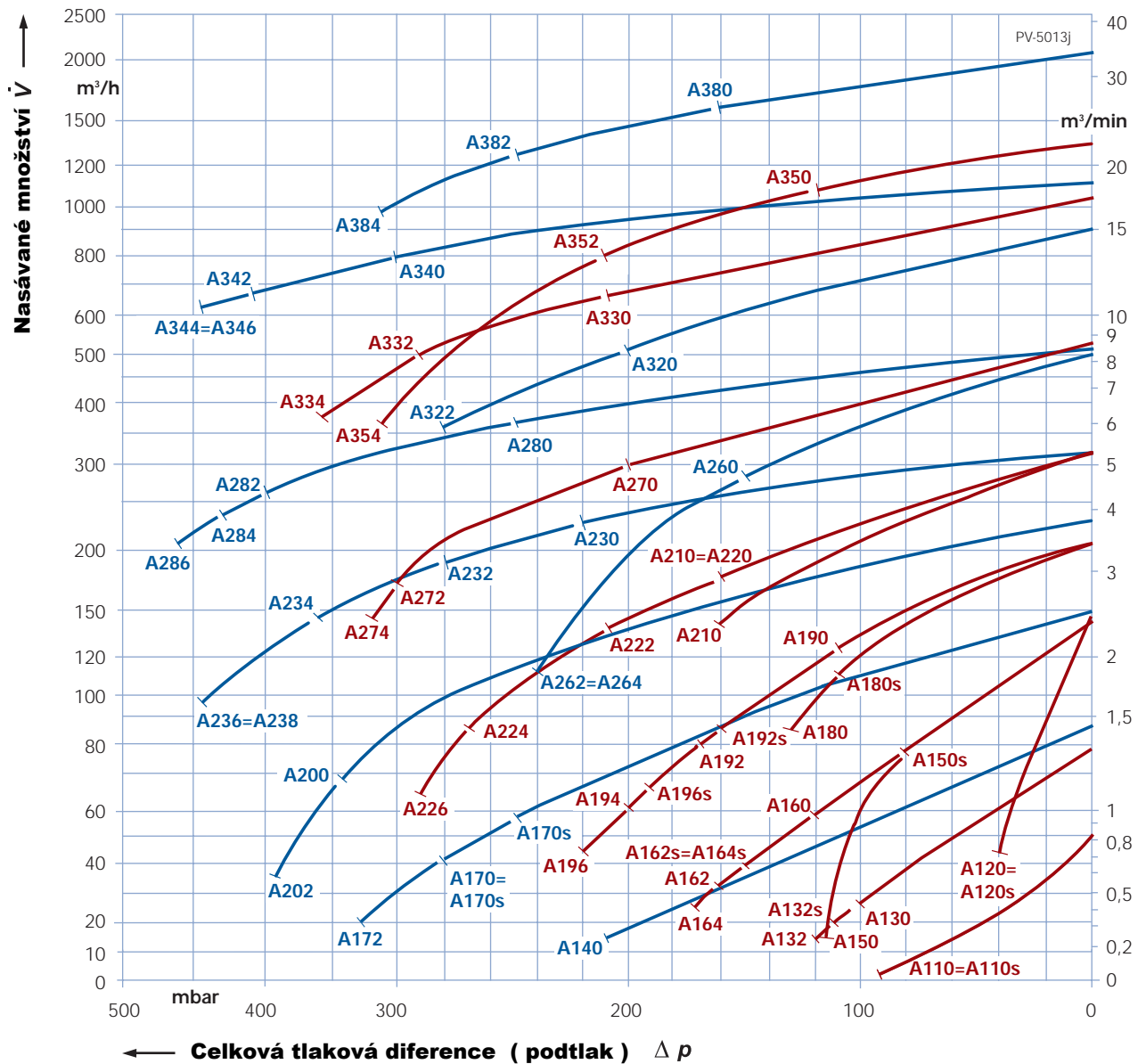

Objednací údaje pro 50 Hz, 3AC, IP55

Pracovní křivka číslo	Motor			Objednací číslo ◦ Je trvale skladem ve výrobním závodě	Hmotnost kg	Hlučnost 1) dB(A)	Podtlakový pojistný ventil 2) ks x typ 2BX2...	Přetlakový pojistný ventil 2) ks x typ 2BX2...
	Výkon kW	Jmenovité napětí 4) V	Proud A					
A110	0,2	200-240 Δ / 345-415 Y	2,1 Δ / 1,2 Y	•2BH1 100-7A H 0 6	7	50	-	-
A120	0,25	200-240 Δ / 345-415 Y	1,38 Δ / 0,8 Y	•2BH1 200-7A H 0 6	8	57	-	-
A130	0,25	200-240 Δ / 345-415 Y	2,1 Δ / 1,2 Y	•2BH1 300-7A H 0 6	8	53	1 x 110/141	1 x 111/143
A132	0,4	200-240 Δ / 345-415 Y	2,6 Δ / 1,5 Y	•2BH1 300-7A H 1 6	10	53	1 x 110/141	1 x 111/143
A140	0,7	200-240 Δ / 345-415 Y	3,8 Δ / 2,2 Y	•2BH1 310-7H H 2 6	14	55	1 x 110/141	1 x 111/143
A150	0,6	200-240 Δ / 345-415 Y	2,8 Δ / 1,6 Y	•2BH1 490-7A H 1 6	14	63	-	-
A160	0,7	200-240 Δ / 345-415 Y	3,8 Δ / 2,2 Y	•2BH1 400-7A H 0 6	13	63	1 x 110/141	1 x 111/143
A162	0,85	200-240 Δ / 345-415 Y	4,2 Δ / 2,4 Y	•2BH1 400-7A H 1 6	15	63	1 x 110/141	1 x 111/143
A164	1,3	200-240 Δ / 345-415 Y	6,6 Δ / 3,8 Y	•2BH1 400-7A H 2 6	16	63	1 x 110/141	1 x 111/143
A170	1,6	200-240 Δ / 345-415 Y	7,5 Δ / 4,3 Y	•2BH1 410-7H H 3 6	24	66	1 x 110/141	1 x 111/143
A172	2,2	200-240 Δ / 345-415 Y	9,7 Δ / 5,6 Y	•2BH1 410-7H H 4 6	27	66	1 x 110/141	1 x 111/143
A180	1,1	200-240 Δ / 345-415 Y	7,5 Δ / 4,3 Y	•2BH1 590-7A H 2 6	21	64	-	-
A190	0,85	200-240 Δ / 345-415 Y	4,2 Δ / 2,4 Y	•2BH1 500-7A H 0 6	18	64	1 x 110/145	1 x 111/147
A192	1,3	200-240 Δ / 345-415 Y	6,6 Δ / 3,8 Y	•2BH1 500-7A H 1 6	20	64	1 x 110/145	1 x 111/147
A194	1,6	200-240 Δ / 345-415 Y	7,5 Δ / 4,3 Y	•2BH1 500-7A H 2 6	21	64	1 x 110/145	1 x 111/147
A196	2,2	200-240 Δ / 345-415 Y	9,7 Δ / 5,6 Y	•2BH1 500-7A H 3 6	25	64	1 x 110/145	1 x 111/147
A200	3	200-240 Δ / 345-415 Y	12,5 Δ / 7,2 Y	•2BH1 510-7H H 4 6	39	72	1 x 110/145	1 x 111/147
A202	4	345-415 Δ	10 Δ	•2BH1 510-7H H 5 7	43	72	1 x 110/145	1 x 111/147
A210	2,2	200-240 Δ / 345-415 Y	12,5 Δ / 7,2 Y	•2BH1 690-7A H 2 6	31	69	-	-
A220	1,6	200-240 Δ / 345-415 Y	8,5 Δ / 4,9 Y	•2BH1 600-7A H 0 6	26	69	1 x 110/145	2 x 111/147
A222	2,2	200-240 Δ / 345-415 Y	10,0 Δ / 5,8 Y	•2BH1 600-7A H 1 6	29	69	1 x 110/145	1 x 111/147
A224	3	200-240 Δ / 345-415 Y	12,5 Δ / 7,2 Y	•2BH1 600-7A H 2 6	34	69	1 x 110/145	1 x 111/147
A226	4	345-415 Δ	9,5 Δ	•2BH1 600-7A H 3 7	42	69	1 x 110/145	1 x 111/147
A230	2,2	200-240 Δ / 345-415 Y	9,7 Δ / 5,6 Y	•2BH1 610-7H H 1 6	42	73	1 x 110/145	1 x 111/147
A232	3	200-240 Δ / 345-415 Y	12,5 Δ / 7,2 Y	•2BH1 610-7H H 2 6	47	73	1 x 110/145	1 x 111/147
A234	4,3	345-415 Δ	10 Δ	•2BH1 610-7H H 3 7	53	73	1 x 110/145	1 x 111/147
A236	5,5	345-415 Δ	13,3 Δ	•2BH1 610-7H H 4 7	70	73	1 x 110/145	1 x 111/147
A238	7,5	345-415 Δ	16,7 Δ	•2BH1 610-7H H 5 7	77	73	1 x 110/145	1 x 111/147
A260	4	345-415 Δ	9,5 Δ	•2BH1 640-7G H 3 7	53	74	1 x 110/145	3 x 111/147
A262	5,5	345-415 Δ	13,3 Δ	•2BH1 640-7G H 4 7	73	74	1 x 110/145	2 x 111/147
A264	7,5	345-415 Δ	16,7 Δ	•2BH1 640-7G H 5 7	86	74	1 x 110/145	1 x 111/147
A270	4	345-415 Δ	9,5 Δ	•2BH1 800-7A H 0 7	112	70	2 x 110	2 x 111
A272	5,5	345-415 Δ	13,3 Δ	•2BH1 800-7A H 1 7	126	70	1 x 110	1 x 111
A274	7,5	345-415 Δ	16,7 Δ	•2BH1 800-7A H 2 7	128	70	1 x 110	1 x 111
A280	5,5	345-415 Δ	13,3 Δ	•2BH1 810-7H H 1 7	163	74	1 x 110	2 x 111
A282	7,5	345-415 Δ	17,6 Δ	•2BH1 810-7H H 2 7	169	74	1 x 110	2 x 111
A284	11	345-415 Δ	28 Δ	•2BH1 810-7H H 3 7	205	74	1 x 110	1 x 111
A286	15	345-415 Δ	32,5 Δ	•2BH1 810-7H H 4 7	221	74	1 x 110	1 x 111
A320	7,5	345-415 Δ	16,7 Δ	•2BH1 840-7J H 2 7	160	74	3 x 110	1 x 151
A322	11	345-415 Δ	28 Δ	•2BH1 840-7J H 3 7	200	74	2 x 110	2 x 111
A330	8,5	345-415 Δ	19,1 Δ	•2BH1 900-7A H 0 7	172	74	1 x 150	1 x 151
A332	12,5	345-415 Δ	28 Δ	•2BH1 900-7A H 1 7	191	74	2 x 110	3 x 111
A334	18,5	345-415 Δ	37 Δ	•2BH1 900-7A H 3 7	204	74	2 x 110	2 x 111
A340	12,5	345-415 Δ	28 Δ	•2BH1 910-7H H 1 7	265	74	1 x 150	1 x 151
A342	16,5	345-415 Δ	35 Δ	•2BH1 910-7H H 2 7	278	74	3 x 110	1 x 151
A344	20	345-415 Δ	40 Δ	•2BH1 910-7H H 3 7	295	74	3 x 110	3 x 111
A346	25	345-415 Δ	52 Δ	•2BH1 910-7H H 4 7	325	74	3 x 110	3 x 111
A350	8,5	345-415 Δ	18,2 Δ	•2BH1 930-7A H 0 7	174	75	1 x 150	1 x 151
A352	12,5	345-415 Δ	28 Δ	•2BH1 930-7A H 1 7	193	75	1 x 150	1 x 151
A354	18,5	345-415 Δ	37 Δ	•2BH1 930-7A H 3 7	206	75	2 x 110	3 x 111
A380	15	345-415 Δ	34 Δ	•2BH1 943-7G H 2 7 ³⁾	270	75	1 x 152	1 x 153
A382	20	345-415 Δ	40 Δ	•2BH1 943-7G H 3 7 ³⁾	300	75	1 x 152	1 x 153
A384	25	345-415 Δ	52 Δ	•2BH1 943-7G H 4 7 ³⁾	330	75	3 x 110	1 x 153

Objednací údaje pro 50 Hz, 1AC, IP55

A110s	0,2	230	1,5	2BH1 100-7A A 0 1	7	50	-	-
A110s	0,2	115 / 230	2,9 / 1,45	2BH1 100-7A V 0 5	7	50	-	-
A120s	0,25	115 / 230	3,1 / 1,6	2BH1 200-7A V 0 5	8	57	-	-
A132s	0,37	115 / 230	5,4 / 2,7	•2BH1 300-7A V 1 5	10	53	1 x 110/141	1 x 111/143
A150s	0,5	230	4,1	•2BH1 490-7A A 1 1	14	63	-	-
A162s	0,8	230	5,2	•2BH1 400-7A A 1 1	15	63	1 x 110/141	1 x 111/143
A164s	1,1	115 / 230	14,6 / 7,3	•2BH1 400-7A V 2 5	16	63	1 x 110/141	1 x 111/143
A170s	1,5	230	9,1	•2BH1 410-7H A 3 1	19	66	1 x 110/141	1 x 111/143
A172s	1,5	115 / 230	22 / 11	•2BH1 410-7H V 4 5	24	66	1 x 110/141	1 x 111/143
A180s	1,2	230	7,9	•2BH1 590-7A A 2 1	21	64	-	-
A192s	1,1	230	6,9	•2BH1 500-7A A 1 1	20	64	1 x 110/145	1 x 111/147
A196s	1,5	115 / 230	22 / 11	•2BH1 500-7A V 3 5	22	64	1 x 110/145	1 x 111/147

Rozměry

Rozměry pro 2BH1 10., 2BH1 20., 2BH1 30., 2BH1 40., 2BH1 49. (mm)

2BH1 200

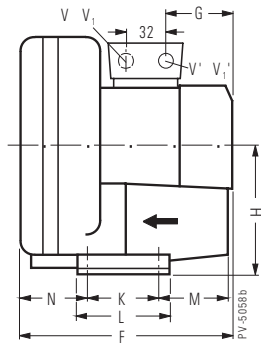
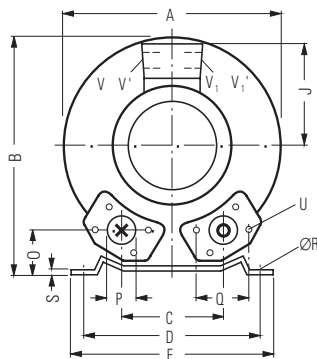

2BH1 10. / 2BH1 30. / 2BH1 40. / 2BH1 49.

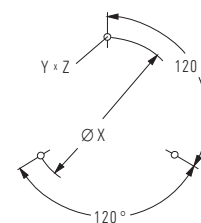
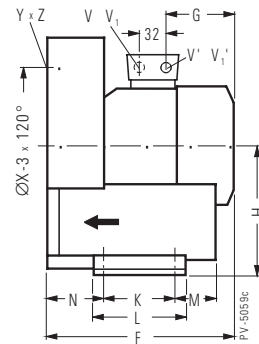
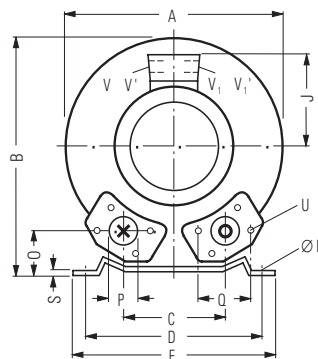

Bohrbild Deckel

Typ	Phasen	Pracovní křivka	A	B	C	D	E	F	G	H	J	K	L	M	N	O	P	Q	Ø R
2BH1 200 - 7AA0. - 2AB0. - 7AH0.	1 ~ 3 ~	A120s A121s A120/121	233	250	110	205	230	244	96 90 92	136	101	83	108	100	75	52	G 1 1/2 (15 tief)	72	10
2BH1 30. - 7A.1. 2BH1 10. - 7A.0. und 2BH1 30. - 7A.0.	1 ~ 3 ~	A132s/133s A130/131 A132/133	246	247	90			256	133	128	111			75	71	39	G 1 1/4 (15 tief)	64	
2BH1 40. - 7A.1. - 7A.2.	1 ~	A162s/163s A164s/165s	285	302	115	225	255	292	156	154	120	95	130	70	75	46	G 1 1/2 (15 tief)	72	12
2BH1 40. - 7A.0. - 7A.1. - 7A.2.	3 ~	A160/161 A162/163 A164/165						269 292	129 153		120								
2BH1 49. - 7AA1. - 7AB1. - 7AH1.	1 ~ 3 ~	A150s A151s A150/151							156										
Typ	Phasen	Pracovní křivka	S	U	V (1 ~)	V' (1 ~)	V1 (3 ~)	V1' (3 ~)	Y x Z	X-Bohrungen	Ø X								
2BH1 200 - 7AA0. - 2AB0. - 7AH0.	1 ~ 3 ~	A120s A121s A120/121	2,5	M 6 x 19	M 16 x 1,5	M 25 x 1,5 Pg 11	-	-	-	-	-								
2BH1 30. - 7A.1. 2BH1 10. - 7A.0. und 2BH1 30. - 7A.0.	1 ~ 3 ~	A132s/133s A130/131 A132/133		M 6 x 17	M 16 x 1,5	M 25 x 1,5	M 25 x 1,5	M 16 x 1,5	M 6 x 15	0°/120°/240°	Ø 140								
2BH1 40. - 7A.1. - 7A.2.	1 ~	A162s/163s A164s/165s	3	M 6 x 19	M 16 x 1,5	M 25 x 1,5	M 25 x 1,5	M 16 x 1,5			Ø 174								
2BH1 40. - 7A.0. - 7A.1. - 7A.2.	3 ~	A160/161 A162/163 A164/165																	
2BH1 49. - 7AA1. - 7AB1. - 7AH1.	1 ~ 3 ~	A150s A151s A150/151			M 16 x 1,5	M 25 x 1,5	M 25 x 1,5	M 16 x 1,5											

Rozměry pro 2BH1 31., 2BH1 41. (mm)

2BH1 31. / 2BH1 41.

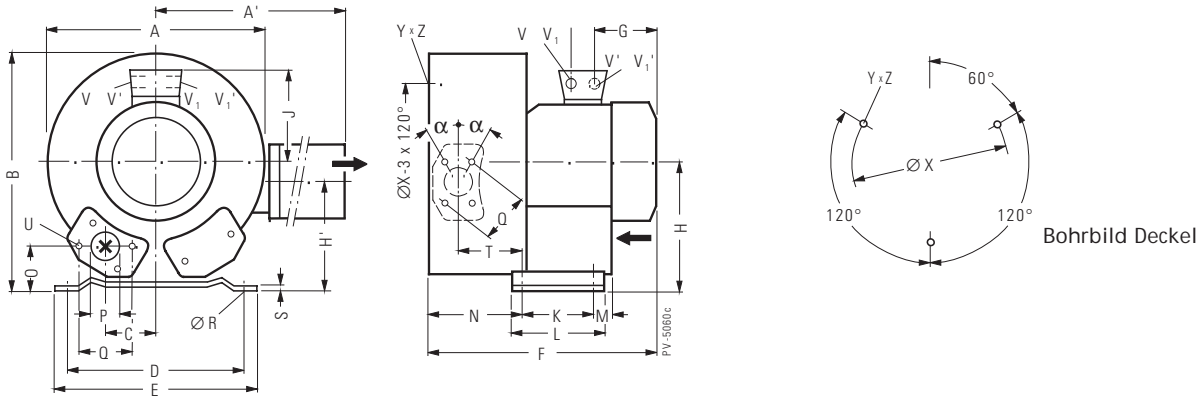

Typ	Phasen	Pracovní křivka	A	A'	B	C	D	E	F	G	H	H'	J	K	L	M	N	O	P	Q
2BH1 31. - 7H.2.	3 ~	A140/141	284	316	270	45	205	230	316	129	128	106	111	83	108	75	130	39	G 1 1/4 (15 tief)	64
2BH1 41. - 7H.3.	3 ~	A170/171	321	321	315	58	225	255	401	185	154	154	128	95	130	70	151	46	G 1 1/2 (15 tief)	72
- 7H.4.		A172/173																		
Typ	Phasen	Kennlinien-Nr.	Ø R	S	T	U	V (1 ~)	V' (1 ~)	V ₁ (3 ~)	V' ₁ (3 ~)	a	Ø X	Y x Z	X-Bohrungen						
2BH1 31. - 7H.2.	3 ~	A140/141	10	2,5	88	M 6 x 17	-	-	M 25 x 1,5	M 16 x 1,5	27°	140	M 6 x 15	51°/171°/291°						
2BH1 41. - 7H.3.	3 ~	A170/171	12	3	106	M 6 x 19	-	M 25 x 1,5	M 16 x 1,5	-	28°	174	M 6 x 15							
- 7H.4.		A172/173				-	-	-	-	-										

Rozměry pro 2BH1 50., 2BH1 59., 2BH1 60., 2BH1 69. (mm)

2BH1 50. / 2BH1 59.
2BH1 60. / 2BH1 69.

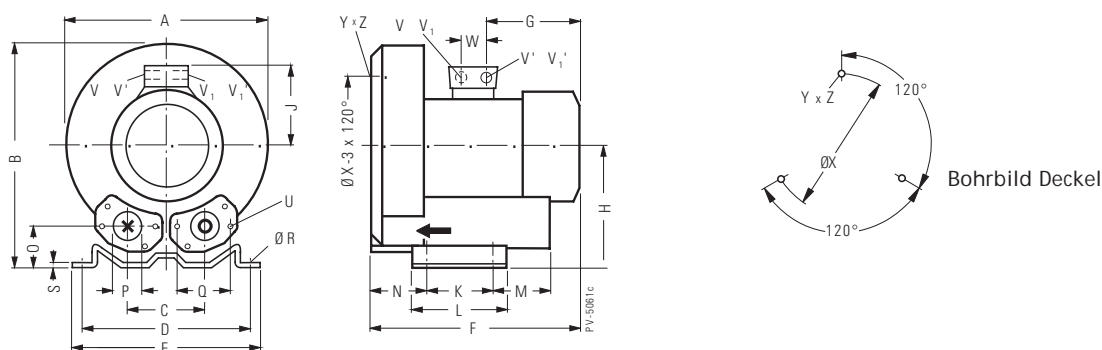

Typ	Phasen	Pracovní křivka	A	B	C	D	E	F	G	H	J	K	L	M	N	O	P	Q	Ø R	
2BH1 50. - 7A.1.	1 ~	A192s/193s	334	337	120	260	295	313	156	175	120	115	155	96	87	48	55	83	14	
		A196s/197s						345	188		128									
2BH1 50. - 7A.0.	3 ~	A190/191						314	153		120									
		A192/193																		
		A194/195						346	185		128									
2BH1 59. - 7AA2.	1 ~	A180s					295	345	188	174,5									15	
		A181s																		
	- 7AE1.	3 ~	A180					314	153		120									
	- 7AH2.	A181						345	185		128									
2BH1 60. - 7A.0.	3 ~	A220	382	384	125	290	325	377		198		140	180	84	109	54				
		A222/223																		
		A224/225						411	190		135									
2BH1 69. - 7A.1.	3 ~	A210						377	85		128									
		A210/211									135									
Typ	Phasen	Pracovní křivka	S	U	V (1 ~)	V' (1 ~)	V ₁ (3 ~)	V' ₁ (3 ~)	Ø X	Y x Z	X-Bohrungen	W								
2BH1 50. - 7A.1.	1 ~	A192s/193s	4	M 8 x 17	M 16 x 1,5	M 25 x 1,5	–	–	200	M 8 x 20	0°/120°/240°	32								
		A196s/197s					–	–												
2BH1 50. - 7A.0.	3 ~	A190/191			–	–	M 25 x 1,5	M 16 x 1,5												
		A192/193			–	–														
		A194/195			–	–														
2BH1 59. - 7AA2.	1 ~	A180s			M 16 x 1,5	M 25 x 1,5	–	–												
		A181s					–	–												
	- 7AE1.	3 ~	A180			–	–	M 25 x 1,5	M 16 x 1,5											
	- 7AH2.	A181			–	–														
2BH1 60. - 7A.0.	3 ~	A220	4,5		–	–			240	M 10 x 20										
		A222/223			–	–														
		A224/225			M 32 x 1,5	M 32 x 1,5	M 32 x 1,5	M 32 x 1,5				42								
2BH1 69. - 7A.1.	3 ~	A210			–	–	M 25 x 1,5	M 16 x 1,5				32								
		A210/211			M 32 x 1,5	M 32 x 1,5	M 32 x 1,5	M 32 x 1,5				42								

Rozměry pro 2BH1 51., 2BH1 61., 2BH1 64. (mm)

2BH1 61.-...4.
-...5.

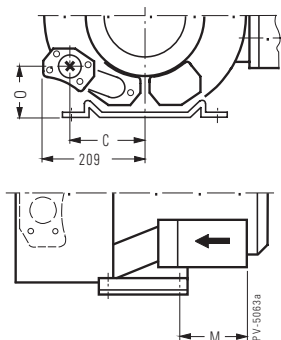

2BH1 51.
2BH1 61.-...1.
-...2.
-...3.

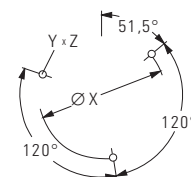
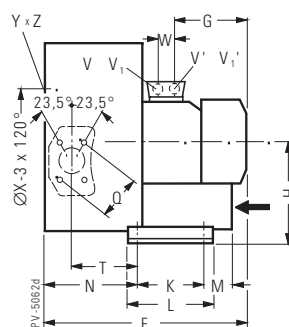
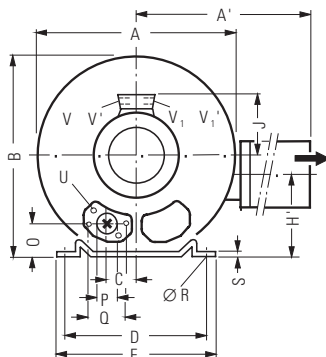

Bohrbild Deckel

Typ	Pracovní křivka	A	A'	B	C	D	E	F	G	H	H'	J	K	L	M	N	O	Ø P	Q
2BH1 51. - 7H.4.	A200/201	372	411	371	60	260	295	465	190	175	144	135	115	155	98	171	48	55	83
- 7H.5.	A202/203							499	224										
2BH1 61. - 7H.1.	A230/231	426	424	420	63	290	325	473	185	198	164	128	140	180	84	205	54		
- 7H.2.	A232/233							507	190			135							
- 7H.3.	A234/235							528	211			148							
- 7H.4.	A236/237				154			570	225			167			225		94		
- 7H.5.	A238/239																		
Typ	Pracovní křivka	Ø R	S	T	U	V	V'	V ₁	V' ₁	Ø X	Y x Z	X-Bohrungen		W					
2BH1 51. - 7H.4.	A200/201	14	4	116	M 8 x 17	4 x M 32 x 1,5				200	M 8 x 20	51,5°/171,5°/291,5°		42					
- 7H.5.	A202/203																		
2BH1 61. - 7H.1.	A230/231	15	4,5	129	M 8 x 17	M 25 x 1,5	M 16 x 1,5	-	-	240	M 10 x 20			32					
- 7H.2.	A232/233													42					
- 7H.3.	A234/235					4 x M 32 x 1,5													
- 7H.4.	A236/237																		
- 7H.5.	A238/239																		

2BH1 64.-...4.
-...5.

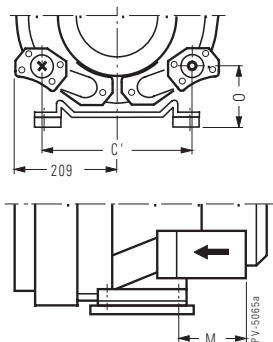

2BH1 64.-...3.

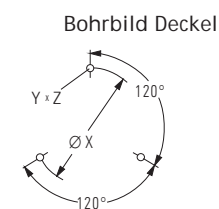
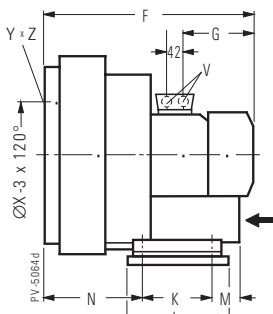
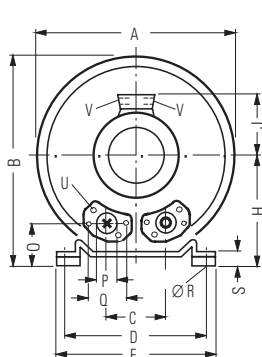

Bohrbild Deckel

Typ	Pracovní křivka	A	B	C	C'	D	E	F	G	H	J	K	L	M	N
2BH1 64. - 7G.3.	A260/261	424	430	125	-	290	325	528	211	218	148	140	188	84	205
- 7G.4.	A262/263			-	309			569	224		167			225	
- 7G.5.	A264/265			-											
Typ	Pracovní křivka	O	Ø P	Q	Ø R	S	U	V	Ø X	Y x Z	X-Bohrungen				
2BH1 64. - 7G.3.	A260/261	74	55	83	15	24,5	M 8 x 17	4 x M 32 x 1,5	240	M 10 x 20	0°/120°/240°				
- 7G.4.	A262/263	114													
- 7G.5.	A264/265														

Rozměry pro 2BH1 80., 2BH1 81., 2BH1 84. (mm)

2BH1 80.

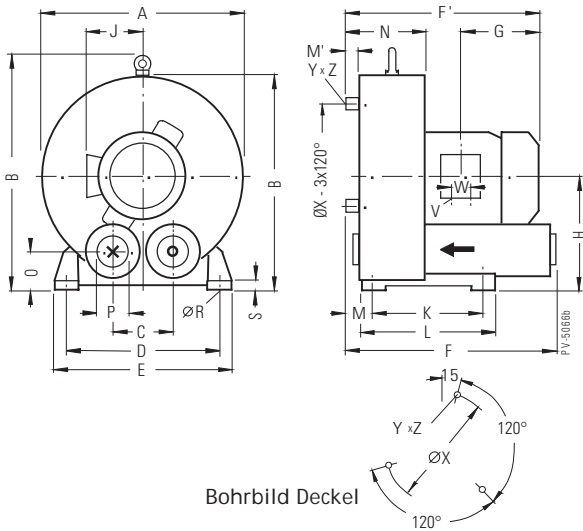

2BH1 81.

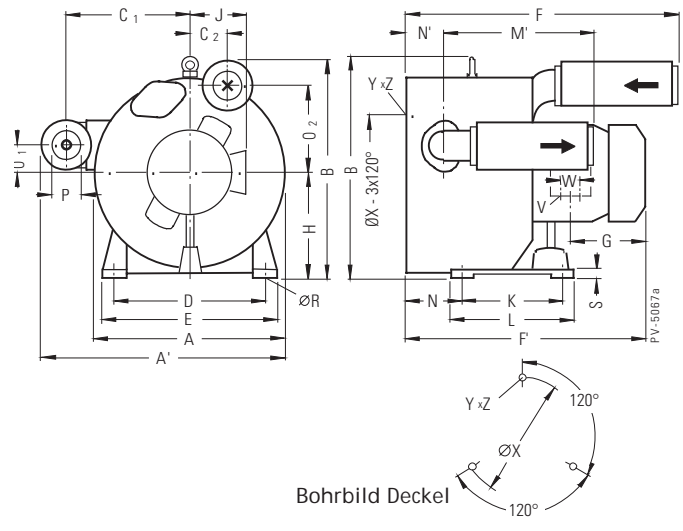

Typ	Pracovní... křivka	A	A'	B	B'	C	C1	C2	D	E	F	F'	G	H	J	K	L	M	M'	N
2BH1 80. - 7A.0.	A270/271	498	-	514	567	145	-	-	365	420	495	470	211	265	148	280	316	35	10	170
- 7A.1.	A272/273											493	224		167					
- 7A.2.	A274/275																			
2BH1 81. - 7H.1.	A280/281	501	636	516	-	318	68,5				601	598						-	402	140,5
- 7H.2.	A282/283																			
- 7H.3.	A284/285						73				726	687	291							
- 7H.4.	A286/287																			

Typ	Pracovní... křivka	N'	O	Q	O ₂	Ø P	Ø R	S	V	W	Ø X	Y x Z	X-Bohrungen
2BH1 80. - 7A.0.	A270/271	-	81	-	-	G 2 1/2	15	22	2 x Pg 21	42	408	M 12 x 20	15°/135°/255°
- 7A.1.	A272/273												
- 7A.2.	A274/275												
2BH1 81. - 7H.1.	A280/281	104	-	66	186	G 2 1/2			4 x M 52 x 1,5				0°/120°/240°
- 7H.2.	A282/283												
- 7H.3.	A284/285				234				4 x M 40 x 1,5	54			
- 7H.4.	A286/287												

2BH1 84 1.

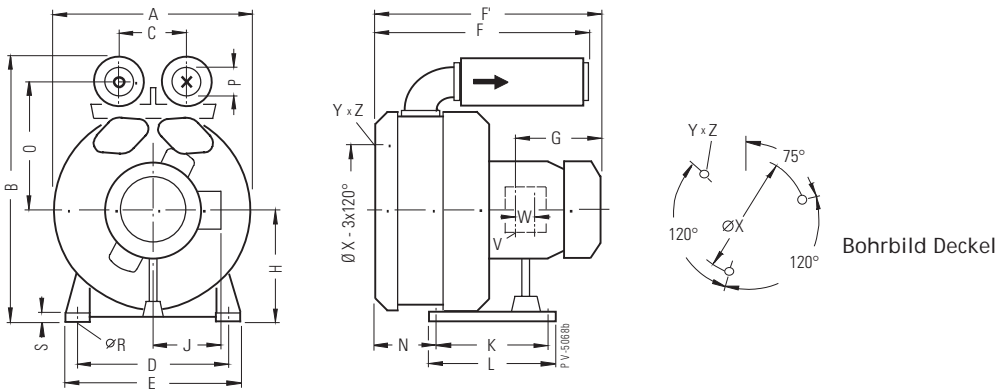

Typ	Pracovní křivka	A	B	C	D	E	F	F'	G	H	J	K	L	N
2BH1 84. - 7J.2.	A320/321	498	652	160	365	420	521	598	224	265	167	280	316	141
- 7J.3.	A322/323							687	291		197			

Typ	Pracovní křivka	O	Ø P	Ø R	S	V	W	Ø X	Y x Z	X-Bohrungen
2BH1 84. - 7J.2.	A320/321	318	G 2 1/2	15	22	4 x M 32 x 1,5	42	408	M 12 x 20	75°/195°/315°
- 7J.3.	A322/323					4 x M 40 x 1,5	54			

Rozměry pro 2BH1 90., 2BH1 91. (mm)

2BH1 90.

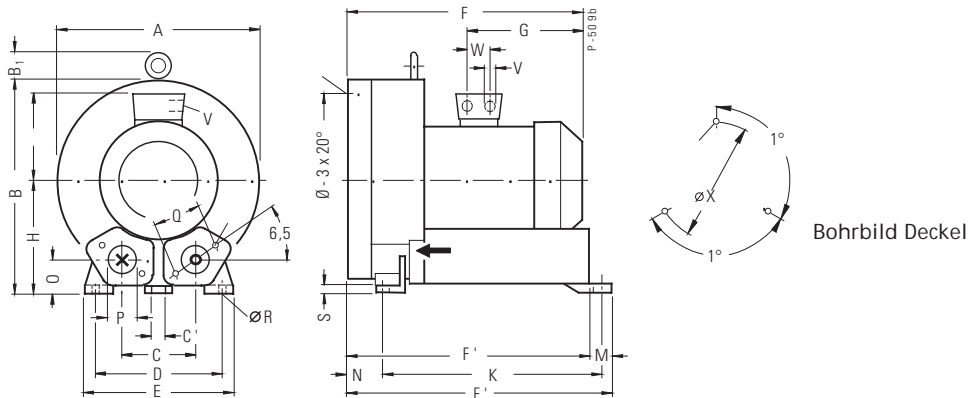

Typ	Pracovní křivka	A	B	B1	C	C'	D	E	F	F'	F''	G	H	J	K	M	N
2BH1 90. und 2BH1 93. - 7A.0.	A330/331	555	570	62	207	15	360	415	543	726	674	266	300	167	596	52	108
- 7A.1.	A332/333								631			345		197			
- 7A.3.	A334/335																
Typ	Pracovní křivka	O	Ø P	Q	Ø R	S	U	V	W	Ø X	Y x Z	X-Bohrungen					
2BH1 90. und 2BH1 93. - 7A.0.	A330/331	91	100	150	15	25	M 12 x 30	4 x M32 x 1,5	42	490	M 12 x 30	0°/120°/240°					
- 7A.1.	A332/333							4 x M40 x 1,5	54								
- 7A.3.	A334/335																

2BH1 91.

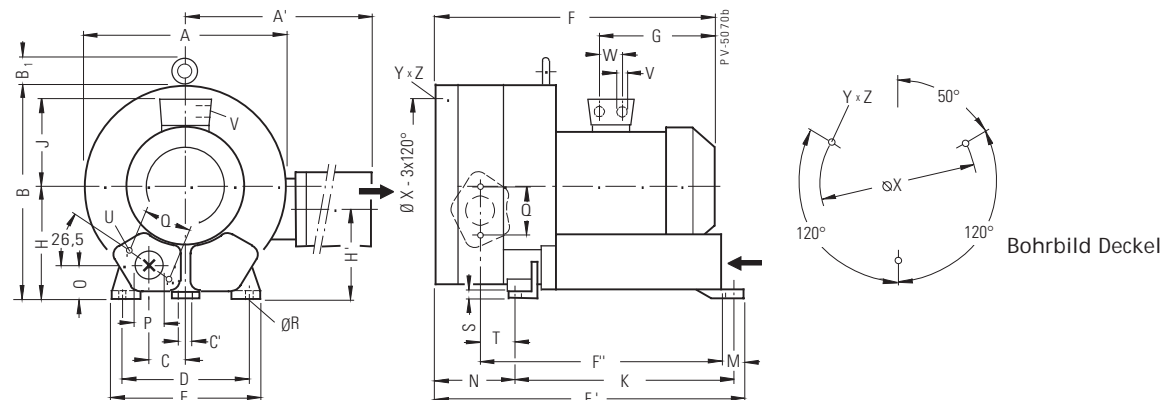

Typ	Pracovní křivka	A	A'	B	B1	C	C'	D	E	F	F'	F''	G	H	H'	J	K	M
2BH1 91. - 7H.1.	A340/341	560	796	580	52	104	15	360	415	765	860	661	291	300	245	197	596	52
- 7H.2.	A342/343																	
- 7H.3.	A344/345																	
Typ	Pracovní křivka	N	O	Ø P	Q	Ø R	S	T	U	V	W	Ø X	Y x Z	X-Bohrungen				
2BH1 91. - 7H.1.	A340/341	242	91	100	150	15	25	95	M 12 x 30	4 x M40 x 1,5	54	490	M 12 x 30	51,4°/171,4°/291,4°				
- 7H.2.	A342/343																	
- 7H.3.	A344/345																	

Rozměry pro 2BH1 943 (mm)

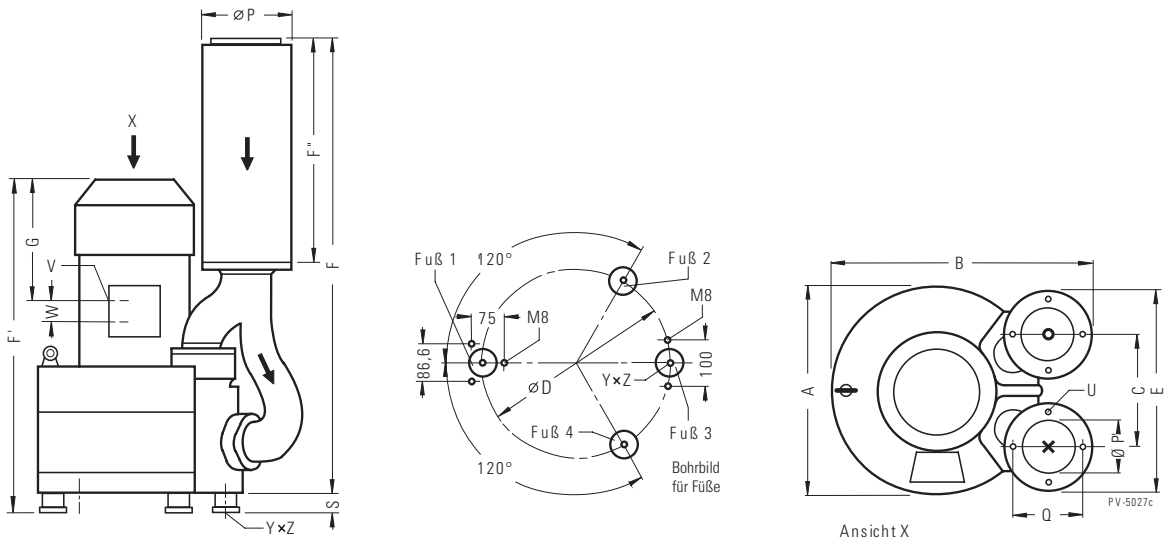

Typ	Pracovní křivka	A	B	C	D	E	F	F'	F''	G	P	P'
2BH1 943 - 7G.2.	A380/381	560	715	307	490	560	1201	765	600	345	252	130
- 7G.3.	A382/383											
- 7G.4.	A384/385							845		385		
Typ	Pracovní křivka	Q	S	U	V	W	Y x Z					
2BH1 943 - 7G.2.	A380/381	210	40	M 16 x 30	2 x M 40 x 1,5	54	M 12 x 10,5					
- 7G.3.	A382/383											
- 7G.4.	A384/385											